

Recluse 6.0

SPIDERCARTS			Ver.	0.1.2.6	Copyright is the property of Spidercarts and shall not be reproduced.
			Authorized	Robert Dicken	
	Recluse Go Kart Plans				

Terms and Conditions

The plans contained on this site are provided as reference material. They are meant to be interpreted as a complete set of step-by-step plans for building the Recluse©. If these drawings and or any details contained within the drawings are used in any way shape or form to create a vehicle by a visitor of this site, Spidercarts.com, the builder will be doing so at their own risk with no guarantee, warranty, or health and safety claims implied or given by Spidercarts.com

By downloading these plans you hold Spidercarts.com, and all owners of that organization harmless from any damages, incidental or otherwise, caused by building or using these plans in any manner. These plans are not warranted for any particular purpose

While every effort has been made throughout the plans available at Spidercarts.com to emphasis the safety aspects of building your own projects the author accepts no liability whatsoever for any damage, injury or loss resulting from the use of these plans. If you have doubts about your ability to safely build your own projects it is recommended that you seek advice from a professional engineer.

The registered owner of Spidercarts.com disclaims all implied warranties, including, without limitations, implied warranties of merchantability, fitness for a particular purpose, and non-infringement.

User License

The author owns all intellectual rights without limitation including copyrights and design rights, covering text, diagrams, illustrations and all other information of any nature displayed in this eBook or contained in the plans available at Spidercarts.com. The purchaser has a limited license and is permitted to use these plans only for guidance on the construction of the various projects on a private non-commercial basis. Any further or alternative use can be considered a breach of the terms of this license and may be actionable.

By purchasing a set of plans, you are obtaining a "license to use" these drawings, images and designs and are agreeing to the terms of this user license. All of my designs are copyrighted property and are licensed, not sold to you. They do not become your property.

The buyer may only use these designs for his/her personal use. The buyer does not assume any proprietary rights. The buyer may not distribute, circulate, copy, burn to CD, photocopy or resell the plans. Legal action will be taken to any individual caught trying to circulate or resell any of the design content.

SPIDERCARTS			Ver.	0.1.2.6	Copyright is the property of Spidercarts and shall not be reproduced.
			Authorized	Robert Dicken	
	Legal Notice				

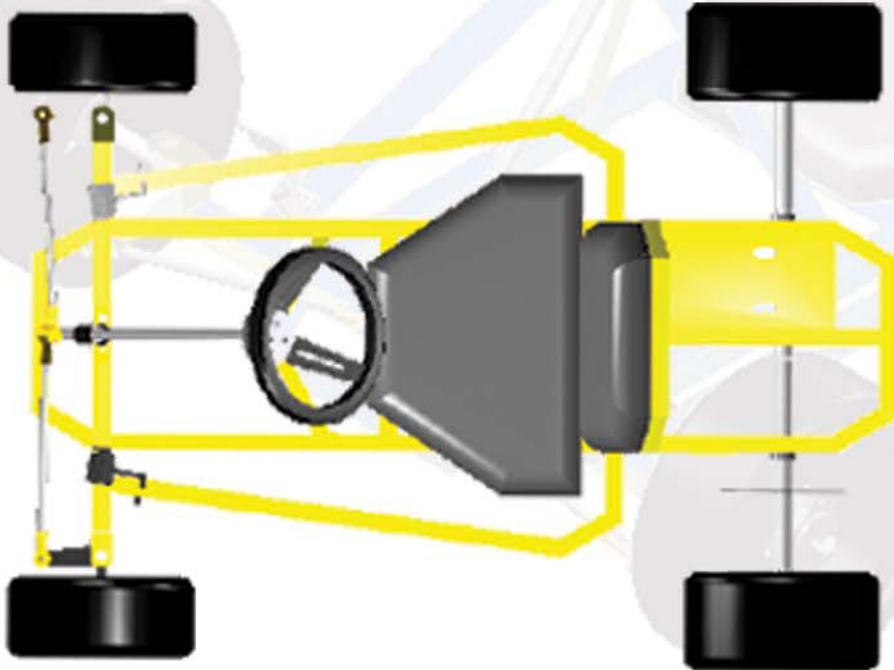

Length	36"
Width	36"
Wheel Base	36"
Wheels Rear	6X5.5
Wheels Front	6X4.5
Tires Rear	11X6.5
Tires Front	10.5X5.5
Clearance	3" to Frame
Chassis	1" #14 Square
Weight	62 Pounds
Motor	6.0 hp Horz Shaft
Transmission	Centrifugal Clutch
Brakes	Disc
Steering	Tie Rods/ Pitman

SPIDERCARTS	1		Ver.	0.1.2.6	Copyright is the property of Spidercarts and shall not be reproduced.
			Authorized	Robert Dicken	
	Specifications				

Here is a list of tools that we used on our first karts.

This list is probably a minimum and any other tools that make your kart building easier would be that much better.

- A truck or trailer. Most of the metal houses carry steel in 20- 24 foot lengths. They will sometimes cut them in half for you for a small charge but even a 12 foot piece of tubing can be hard to get home in moms minivan.
- We are going to need to measure and mark this new metal, so a tape measure and some good soap stone or a silver sharpie will be needed.
- Cutting the metal can be done in a wide variety of ways. I would suggest a chop saw. They are not to expensive and very easy to use. Most of them have a angle guard so you can set it for different degrees when cutting.
- After cutting the metal there is usually very sharp edges. Now you can get a grinder and grind them all smooth or just be very careful with the cut metal till you weld it all together. The welding will melt the rough edges and you wont have to worry about them any longer. Your Choice!
- Some Vice grip clamps are handy to use as extra hands if you are tackling this project solo. Sometimes its nice to have another hand.
- We must hook all this metal together somehow, so a welder is a must. Now using 14 gauge metal it doesn't have to be anything to big but more power is always better than not enough. If you don't weld or have a welder handy, you can always take it to your local welder and have him put it together for you. They might charge a bit but its good work!
- Protective gear is a must! Get some good gloves. Get some good eye protection. Always think safety first. There is no fun in getting hurt.
- Well the rest of the tools should be hanging out around the shop or garage. Socket sets, hammers, pliers, drills and drill bits, wire brush, hand grinder and maybe some painting supplies. Well that should get us started. Lets get to work.

SPIDERCARTS			Ver.	0.1.2.6	Copyright is the property of Spidercarts and shall not be reproduced.
			Authorized	Robert Dicken	
		Tools			

Materials Needed

Below are the materials needed to complete all the cutting, fabrication and welding portions of building your new kart. There is a lot more that needs to go on it after it is built such as bearings, tires and wheels, motor, etc.

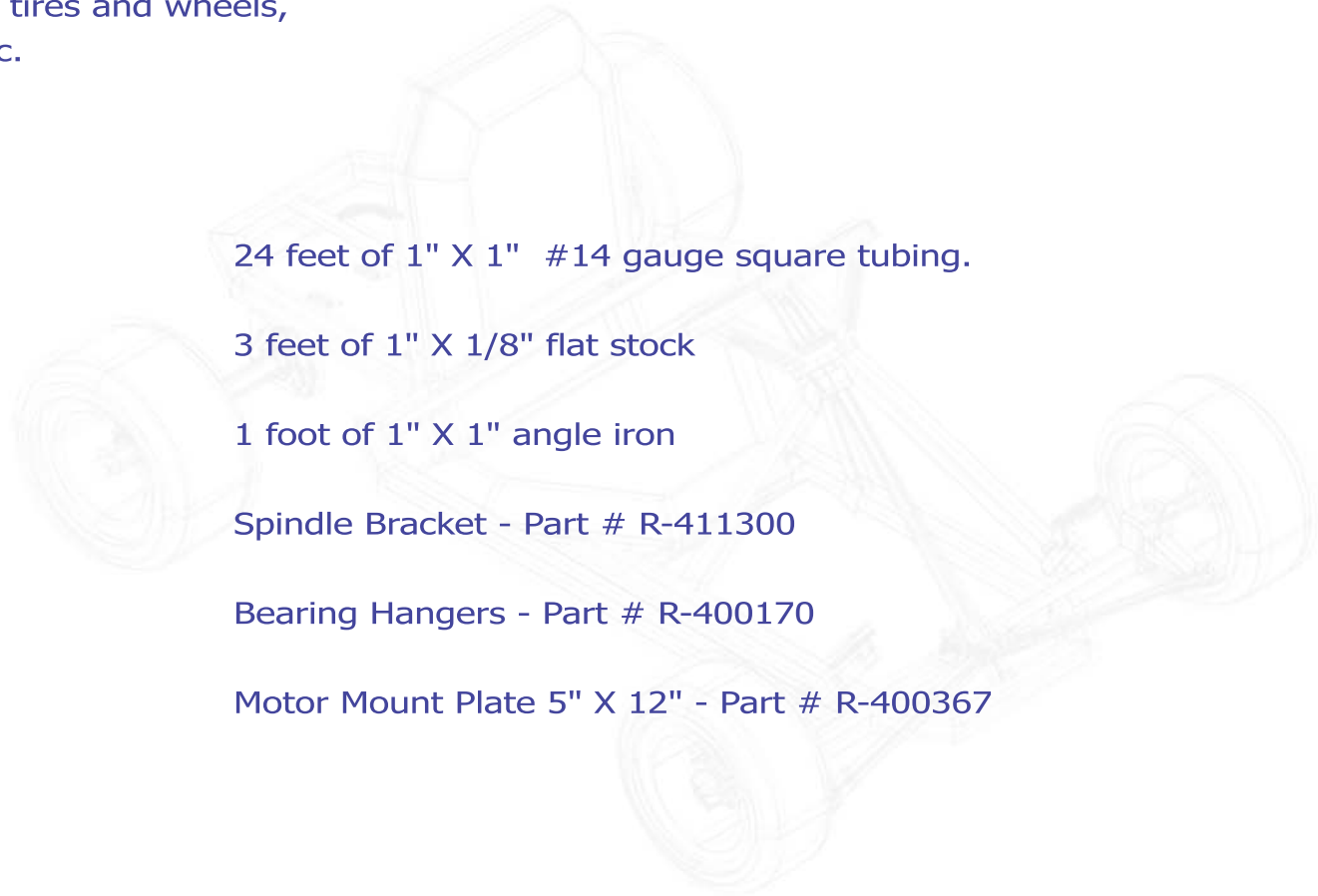

24 feet of 1" X 1" #14 gauge square tubing.

3 feet of 1" X 1/8" flat stock

1 foot of 1" X 1" angle iron

Spindle Bracket - Part # R-411300

Bearing Hangers - Part # R-400170

Motor Mount Plate 5" X 12" - Part # R-400367

SPIDERCARTS			Ver.	0.1.2.6		Copyright is the property of Spidercarts and shall not be reproduced.
			Authorized	Robert Dicken		
		Materials				

Step By Step

1 - 7

1 - Buy your metal from your Materials list.

2 - Make sure you have all the right Tools or you can borrow them.

3 - Measure, cut and drill all the parts from the Diagrams

4- Start with welding the base-frame together. Make sure you have a nice flat welding surface so you can get all your welds straight and even.

5 - Now weld the sub-frame. Don't worry about the bearing hangers and brake bracket for now. You can do those to custom fit your hardware.

6 - Next you will need to weld the base-frame to the sub-frame. It is very important that these two are straight with each other. If one or the other is a bit off that's OK as long as this weld is right. * So to make it right you will need to measure from part # R-2130 to Part #R-2290 on both sides and make sure the numbers are the same before you weld it together. See the Diagram. Use blocks to get your sub-frame the right height and level so you don't have to hold it all together while you are welding.

7 - I would now weld in your side rails. That is part #255_00. It is a bit tricky. It angles down as well as inward. So you will have some real different angles to cut. My advise is to start out with a 26" piece and hold it in place once you have the base-frame and sub-frame together and mark your lines and angles there on the spot. You can then cut them perfect and weld them into place.u to fit your needs. You might even put a les expensive Band style brake if you are on a budget.

SPIDERCARTS			Ver.	0.1.2.6	Copyright is the property of Spidercarts and shall not be reproduced.
			Authorized	Robert Dicken	
	Step By Step / 1-7				

Step By Step

8-10

8 - Now you can make your seat back or "roll bar". It is shown in the Connect diagram in the top left corner. You will need to grind down the ends of the two R-1290's you should have left to create about a 15° angle. Any more than that and your motor will not mount properly. In fact you might want to weld it on last, after you have the motor in place to make sure you have the distance needed to adjust your chain and such.

9 - OK lets put on the bearing hangers and brake bracket if you haven't already done so. The hangers need to be welded straight and lined up. You measure 1" from the end of the R-1290 you are welding to. And that's where you will weld the hanger. The brake bracket goes 5" 3/4 back on the outside of the R-1290. The brake bracket is a very custom part as there are many different models you could have so adjust the part I have shown you to fit your needs. You might even put a les expensive Band style brake if you are on a budget.

10 - Steering is a must! Weld the steering brackets into place as shown. I weld the front bracket part # R-stbrkt1 first. Measure 5/8" from the center of part #2290. You should end up with 1" 1/4 between the two brackets. Then I put my actual steering shaft into place to get the right angles for the # R-stbrkt14. At this point you can "to a point" adjust the angle and how far back you steering wheel it from the driver. I cut my steering shaft to 18" 3/4 long, and that is the right length for what you see in the Diagram. The steering bracket will fit best at about 11" 1/2 from the front of part # R-2730 at about 16° angle.

SPIDERCARTS			Ver.	0.1.2.6	Copyright is the property of Spidercarts and shall not be reproduced.
			Authorized	Robert Dicken	
	Step By Step / 8-10				

Step By Step

11-14

11 - At this point you may want to put all your hardware on to make sure it all fits and there is no other adjustments. You might need to drill some holes for the extras if you decide to "Pimp your Ride". If its all good take it all back off and get it ready to paint.

12 - Clean up all your weld with a grinder, flap wheel, wire wheel, or wire brush. For cleaning I use laundry detergent and hot water to cut the oils and grease off the metal. Be sure to dry it very good with a lint free cloth.

13 - For paint selection I use a hammered finish paint and it works great and hides any ugly sanding marks or bad looking welds with its textured look and still gives it a shiny finish. Pick a cool color and give it a coat or two.

14 - Put all your hardware back on and enjoy your new kart.

Have Fun!

SPIDERCARTS			Ver.	0.1.2.6	Copyright is the property of Spidercarts and shall not be reproduced.
			Authorized	Robert Dicken	
	Step By Step / 11-14				

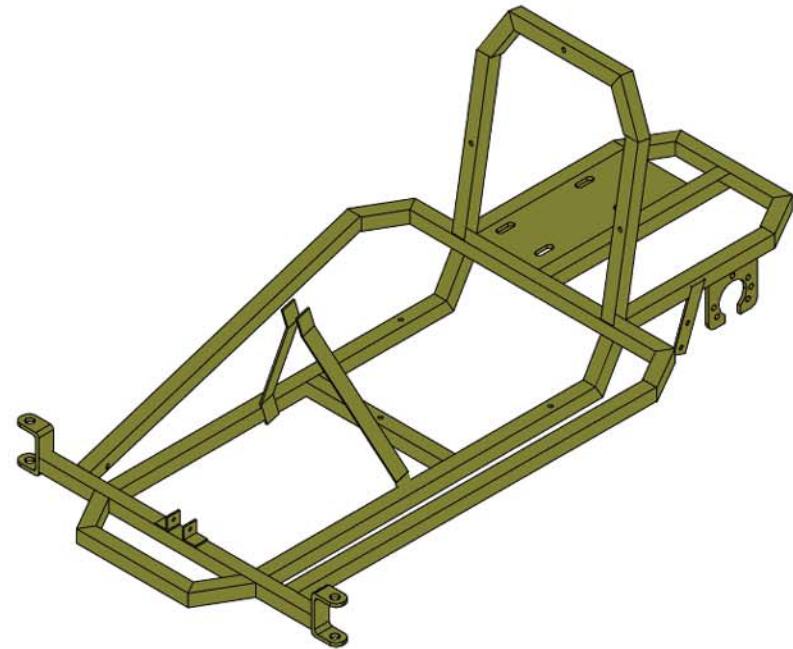
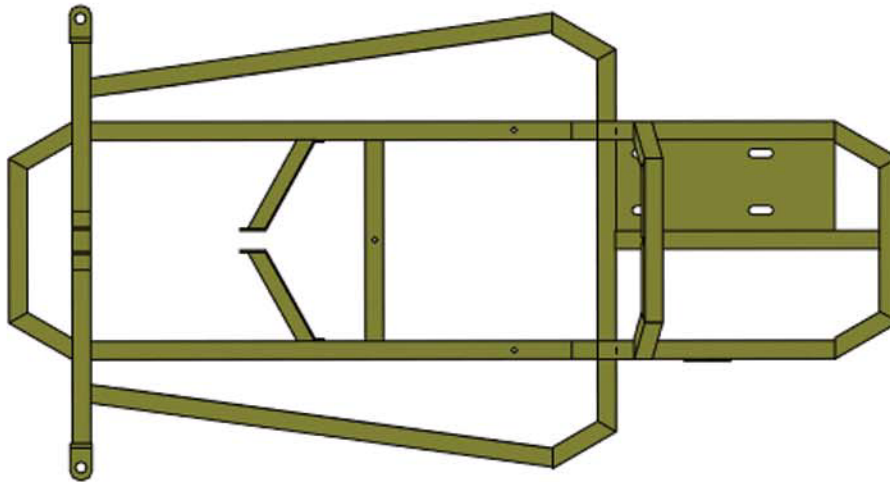
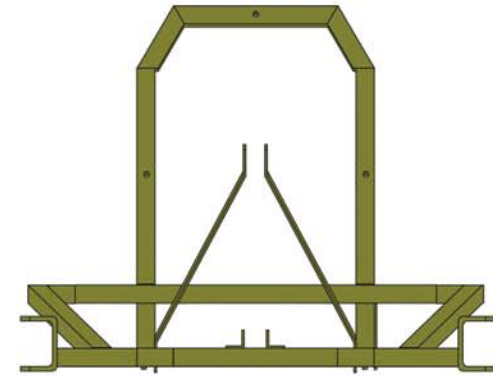
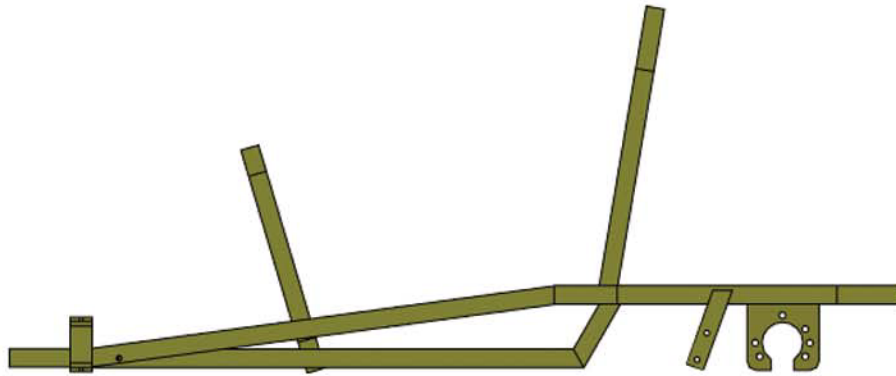

SPIDERCARTS	2		Ver.	0.1.2.6	Copyright is the property of Spidercarts and shall not be reproduced.
			Authorized	Robert Dicken	
	Total Weld w/ Roll Bar				

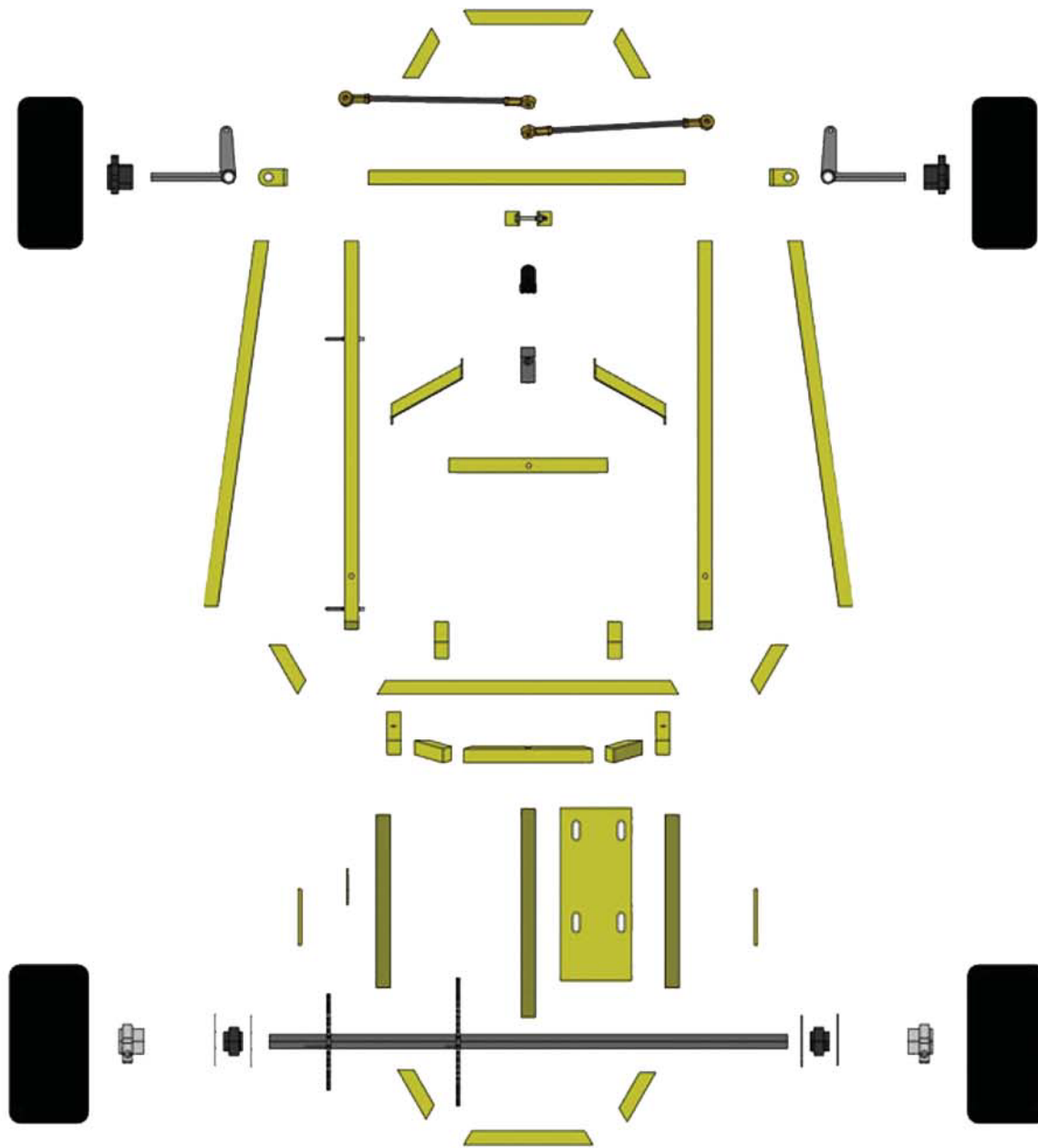

SPIDERCARTS

Ver.

0.1.2.6

Authorized

Robert Dicken

Exploded View

Copyright is the property of Spidercarts and shall not be reproduced.

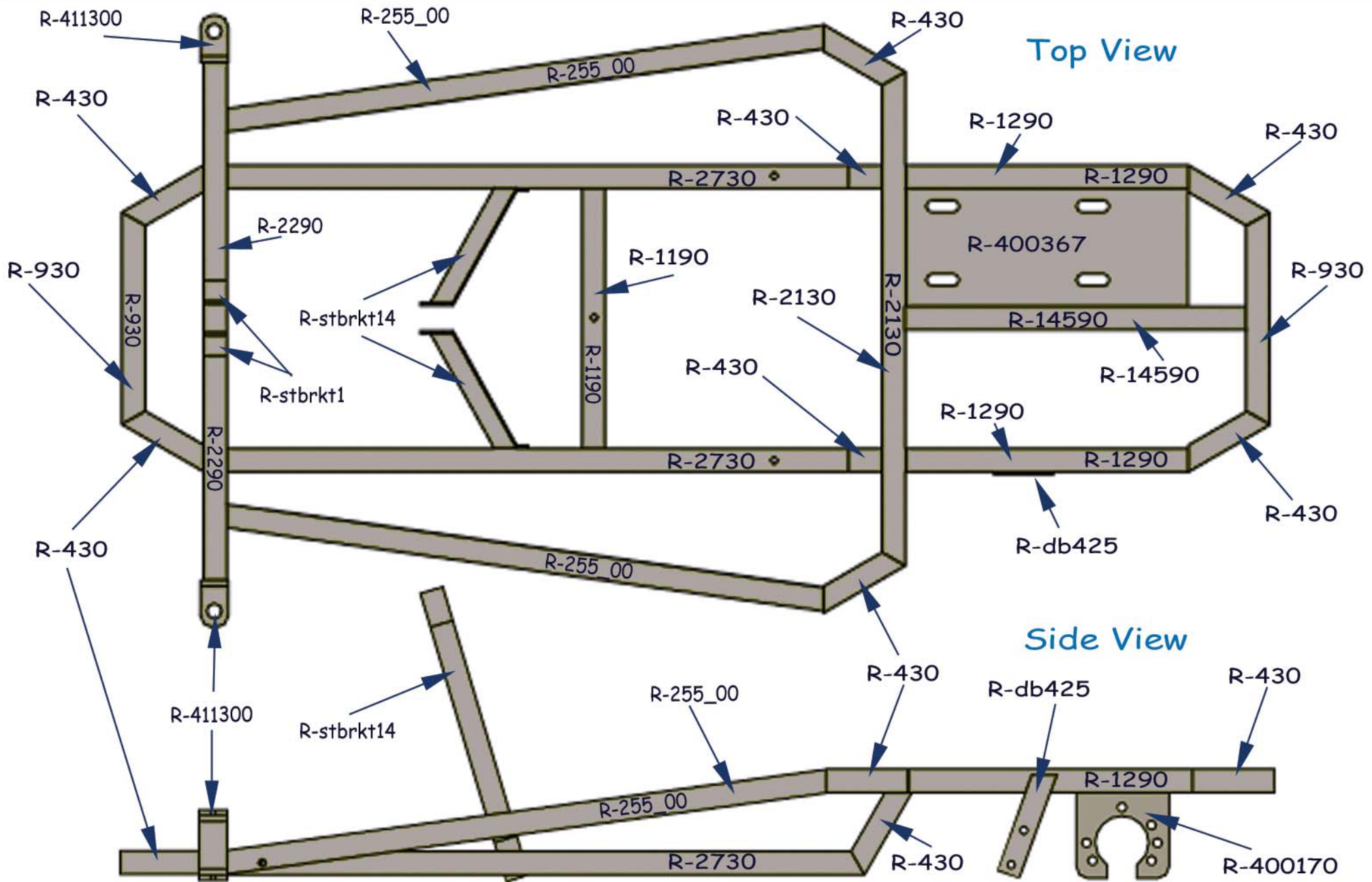

SPIDERCARTS	13	Ver.	0.1.2.6	Copyright is the property of Spidercarts and shall not be reproduced.
		Authorized	Robert Dicken	
	Parts Labeled		Total	

Side View

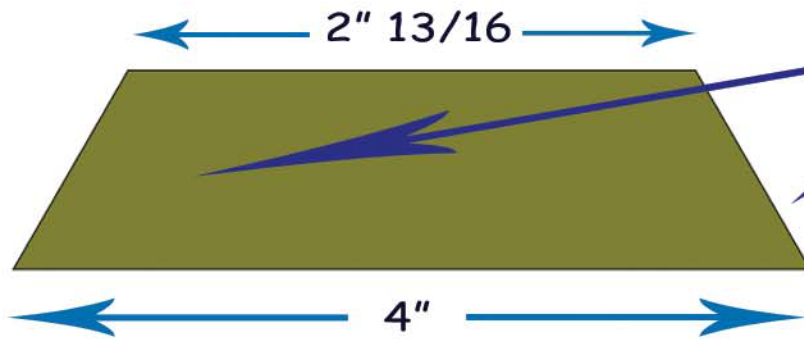

30° Angle Cut

Notes

This is a part you need to enjoy building!! You will need to make 10 of these! It is cut from our 1"x1" 14 Metal stock. Just cut a 30° angle, measure 4" and cut another 30° angle mirrored to the first one. That's it! Make yourself a bunch of these and go to the next step. This is Part Number R-480

Top View

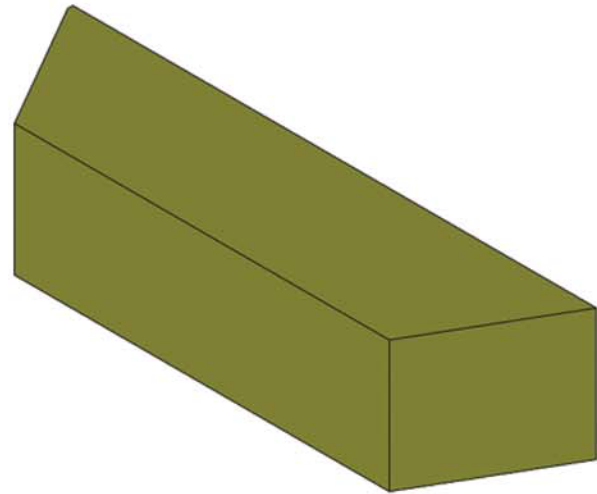
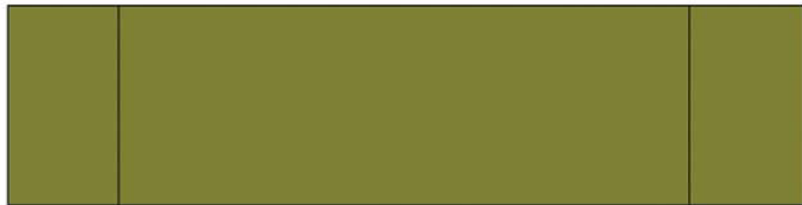

SPIDERCARTS	3		Ver.	0.1.2.6		Copyright is the property of Spidercarts and shall not be reproduced.
			Authorized	Robert Dicken		
		Parts / R-430		Qty-10		

Side View

30° Angle Cut

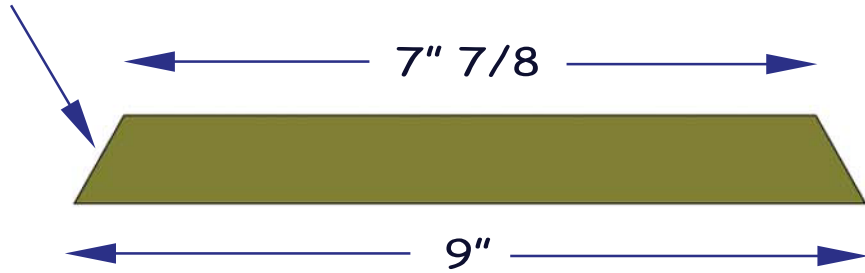

Notes

This is very close to the R-430 but you will cut it to 9" instead of 4". We will use this for the front bumper. Just cut a 30° then measure 9" and cut another 30° but make it mirror the other side. That's it! We will only need 1 of these. This is Part Number R-930

Top View



Iso View

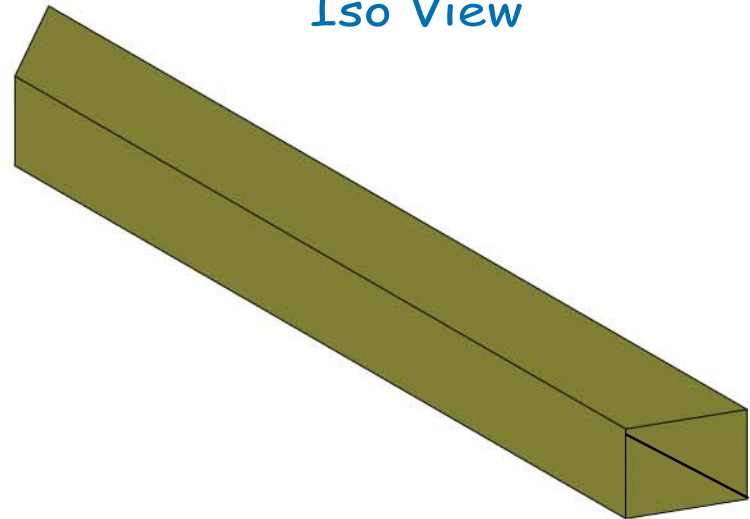

SPIDERCARTS	4		Ver.	0.1.2.6		Copyright is the property of Spidercarts and shall not be reproduced.
			Authorized	Robert Dicken		
	Parts / R-930			Qty-3		

Side View

90° Angle Cut

Drill a 5/16 hole through this one for seat mounting. Center is 5"1/2 from the end.

Notes

These might be the most simple parts we have on the kart. There are a few versions of this we will be making. These are all just straight flat cuts. Measure the given distance and cut. Thats it! You will need 1 of the R-1190, 4 of the R-1290 and 1 of the R-14590.

Iso View

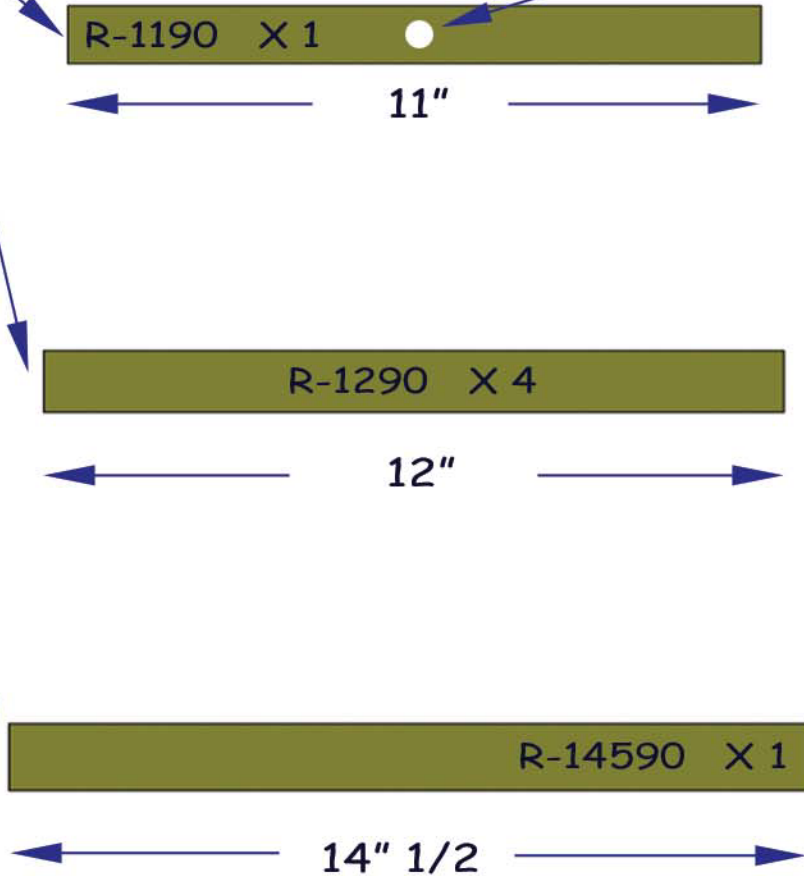
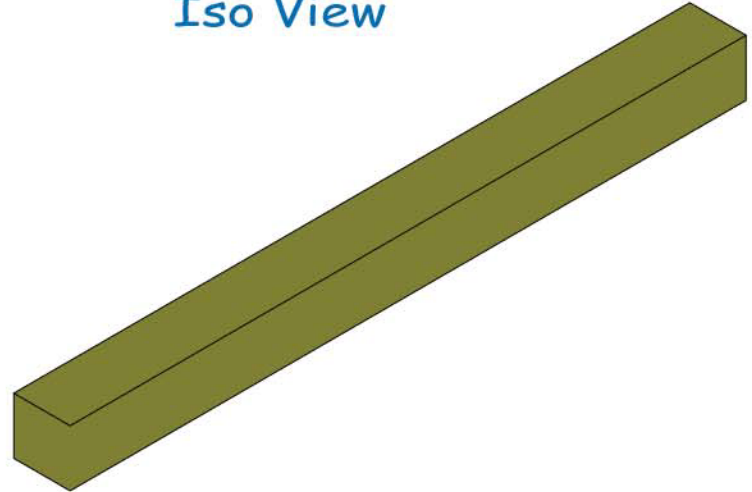

SPIDERCARTS	5		Ver.	0.1.2.6		Copyright is the property of Spidercarts and shall not be reproduced.
			Authorized	Robert Dicken		
		R-1190, 1290, 14590		Qty-1,4,1		

Side View

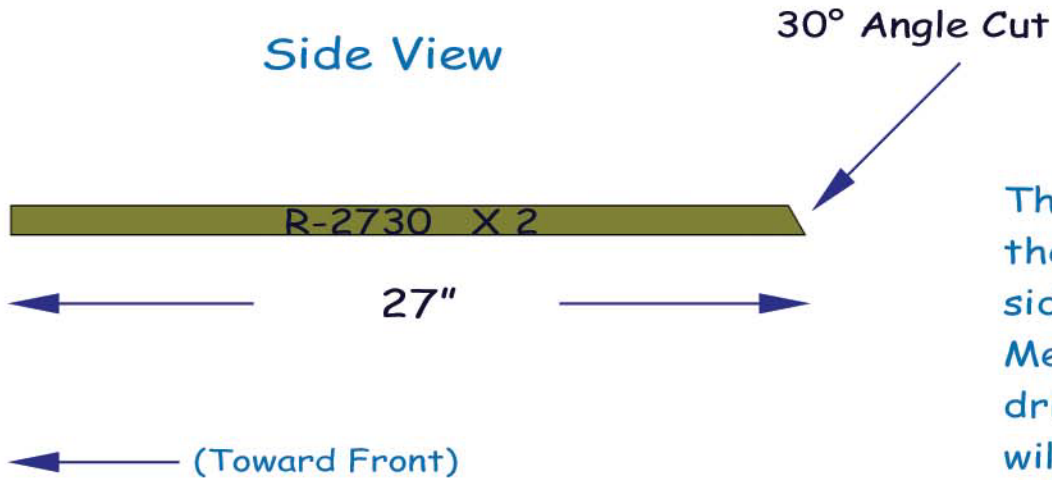

Notes

This part is your base frame. Cut a 90° then measure 27" and cut a 30°. The 90° side will be the front of the kart. Measure 24" back from the front and drill a 5/16 hole all the way through. We will use this later to bolt the seat on. We will only need 2 of these. This is Part Number R-2730

Top View

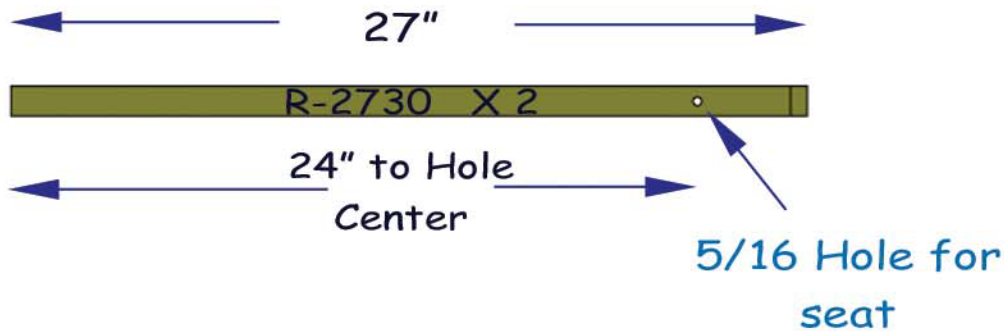

Iso View

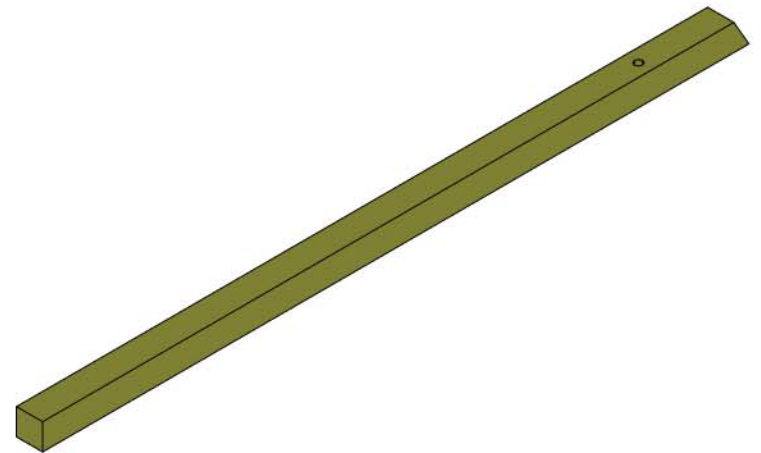

SPIDERCARTS	6		Ver.	0.1.2.6		Copyright is the property of Spidercarts and shall not be reproduced.
			Authorized	Robert Dicken		
		Parts / R-2730		Qty-2		

30° Angle Cut

30° Angle Cut

Side View

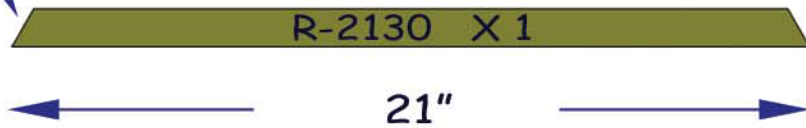

Notes

This is the front of your sub-frame. Cut a 30° angle then measure 21" and cut another 30° angle that mirrors the first. We will only need 1 of these. This is Part Number R-2130

Top View

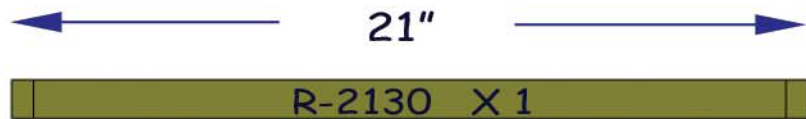

Iso View

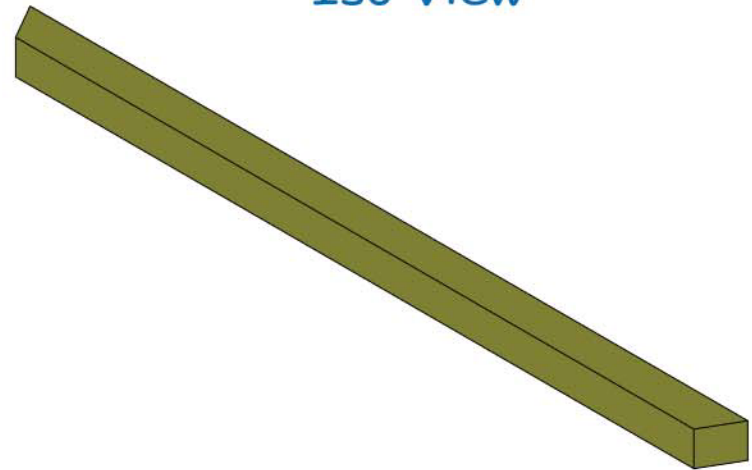

SPIDERCARTS	7		Ver.	0.1.2.6		Copyright is the property of Spidercarts and shall not be reproduced.
			Authorized	Robert Dicken		
	Parts / R-2130			Qty-1		

90° Angle Cut

90° Angle Cut

Side View



Notes

This is the front of your kart. Cut a 90° on both ends. 22" is the total length. Make sure your cuts are straight on this one, we will be welding the spindle brackets to the ends later. You will only need 1 of these. This is Part Number R-2290

Top View

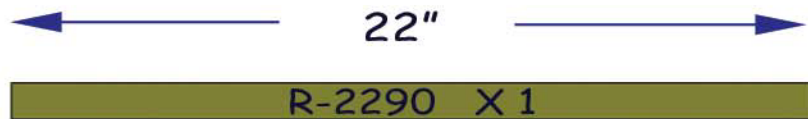

Iso View

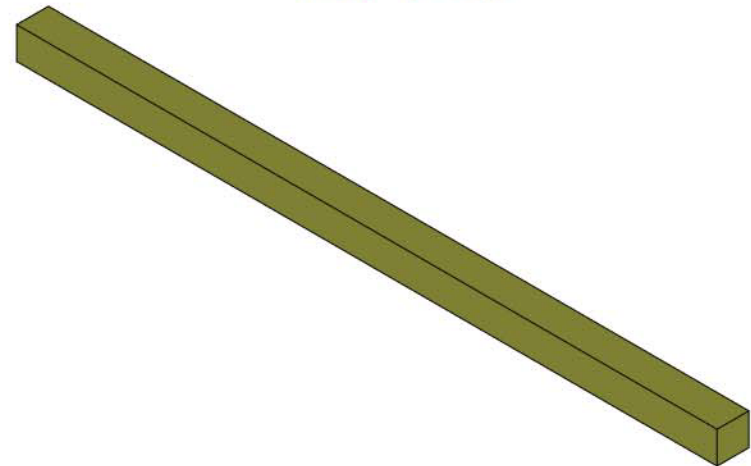

SPIDERCARTS	8		Ver.	0.1.2.6		Copyright is the property of Spidercarts and shall not be reproduced.
			Authorized	Robert Dicken		
	Parts / R-2290			Qty-1		

Drill 5/16" Hole Centered

1/2" from end

1 1/2" Till Bend

1 5/8" Till Bend Point

Notes

OK this is where we use that flat metal. It should be 1" wide and at least 3/16" thick. This will take a bit of fabrication and can be changed to fit your needs. I like to measure my points then cut the metal half way through where I need to bend it. After I bend it I run a weld bead where I cut it to give it strength again. Just a tip that works for me. You will need 2 of these. This is Part Number R-stbkt14

Steering Wheel side
bolted to Steering header

Bottom Side
welded to frame

13 7/8"

Top View

13 7/8"

R-stbkt14 X 2

10 3/4"

5"

Iso View

SPIDERCARTS

8

Ver.

0.1.2.6

Authorized

Robert Dicken

Parts / R-stbkt14

Qty-2

Copyright is the property of Spidercarts and shall not be reproduced.

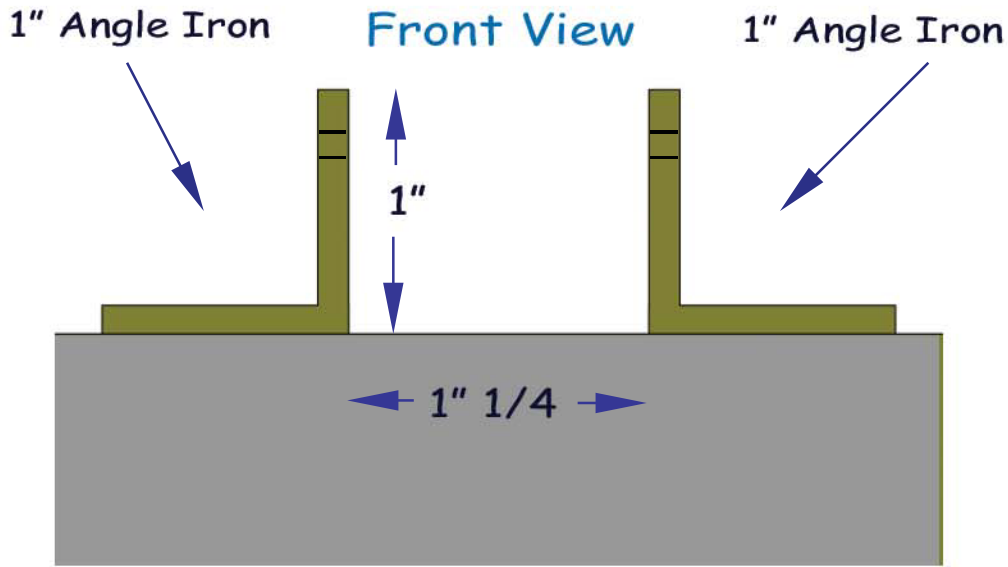

Notes

This is the front steering Bracket. Very easy to make. Take that piece of 1" angle iron and cut yourself two 1" sections. Then drill a 5/16 hole 11/32" from the top edge. These will weld right to R-2290. This is part R-stbrkt1.

Drill 5/16" Hole for mounting Steering

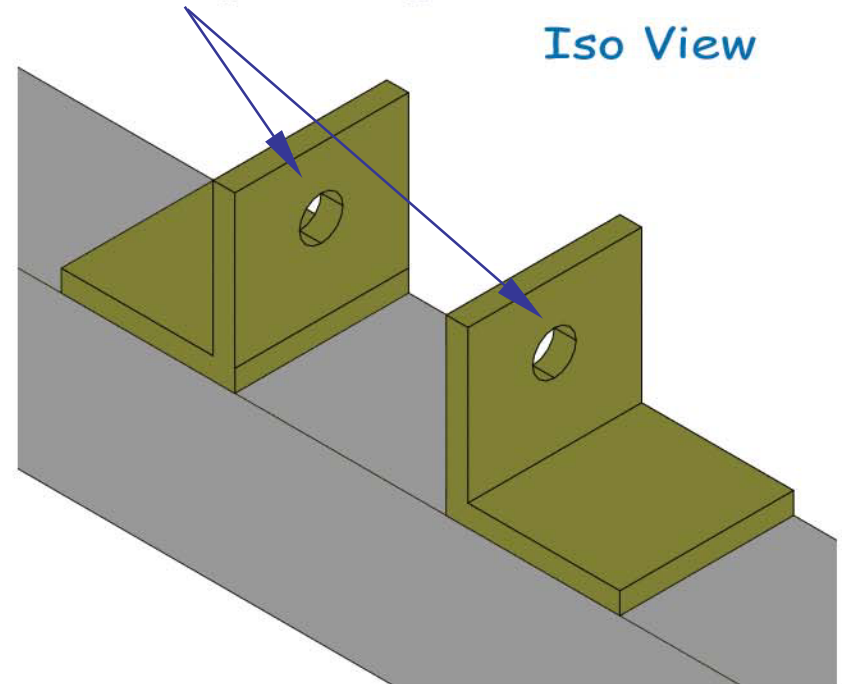
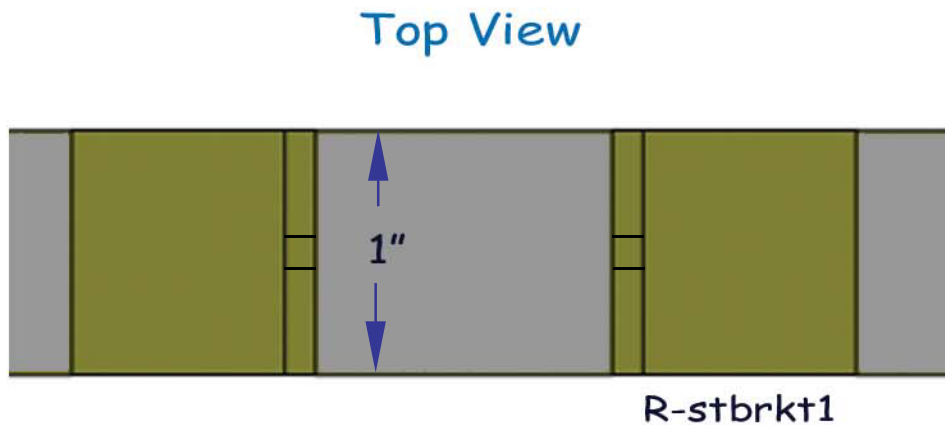

SPIDERCARTS	19		Ver.	0.1.2.6	Copyright is the property of Spidercarts and shall not be reproduced.
			Authorized	Robert Dicken	
	Parts / R-stbrkt1 X 2		Qty-2		

Side View

25° Angle Cut

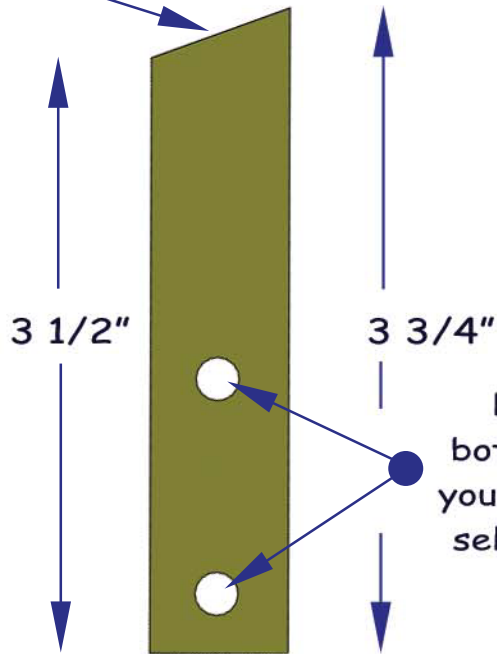

Drill holes 1/2" from the bottom and space them to fit your disc brake. The brake we sell is set at 1" 9/16 Centers.

R-db425 X 1

Notes

This is the bracket for the disc brakes. This is also made from the flat 1" X 3/16". Cut your straight side then measure 3 3/4" and cut your 25° angle. This will weld to the subframe. You will only need 1 of these. This is Part Number R-db425

Iso View

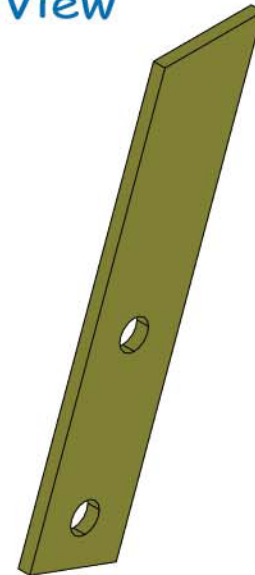

SPIDERCARTS	19		Ver.	0.1.2.6	Copyright is the property of Spidercarts and shall not be reproduced.
			Authorized	Robert Dicken	
	Parts / R-db425			Qty-1	

Notes

This is your side rail. It is the hardest to get the angles right, because it is a compound angle. So I save it for last in my cutting and welding steps. Once everything is welded together, start with a 26" cut and hold it into place. Then mark the angles you need. This way if you are off on any of your measurements you can soak it up with this piece. You will need 2 of these and this is part number

Side View

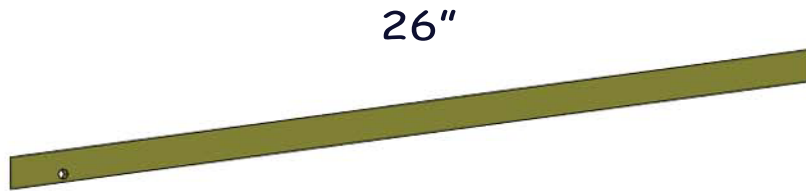

26"

R-255_00 X 2

Top View

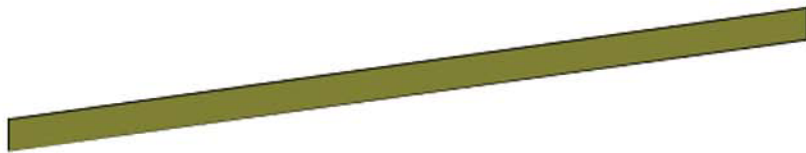

Iso View



SPIDERCARTS	20		Ver.	0.1.2.6		Copyright is the property of Spidercarts and shall not be reproduced.
			Authorized	Robert Dicken		
	Parts / R-255_00			Qty-2		

Bearing Hangers

The bearing hangers are so cheap I would suggest just buying them from a supplier. You can get the entire set with the bearings, hangers, and hardware for under \$50.00. The hangers are what we call a weldment and get welded directly onto the frame. Then the bearings and hardware bolt right on to the hanger..



SPIDERCARTS	23		Ver.	0.1.2.6		Copyright is the property of Spidercarts and shall not be reproduced.
			Authorized	Robert Dicken		
		Hangers / R-400170		Qty - 2		

Spindle Brackets

This is another weldment. The spindles are what you attach your front wheels to and the spindle brackets hold the spindles. These are also very cheap to buy as a kit. I would suggest just buying them from a supplier. You can get the entire set for under \$40.00.



SPIDERCARTS	23		Ver.	0.1.2.6	Copyright is the property of Spidercarts and shall not be reproduced.
			Authorized	Robert Dicken	
		Hangers / R-411300		Qty - 2	

Side View

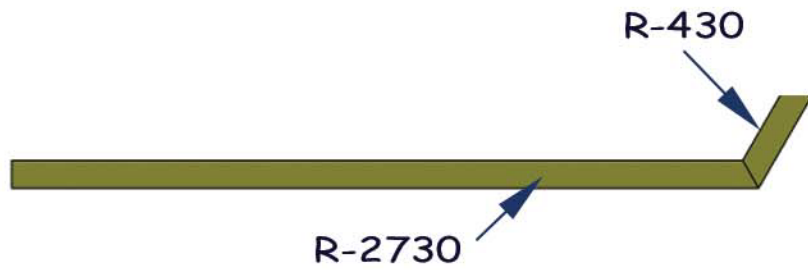

Front View

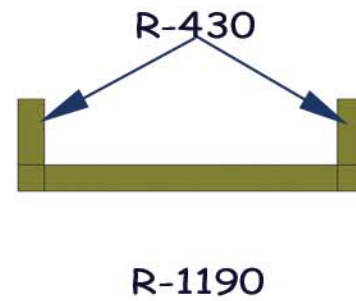

Top View

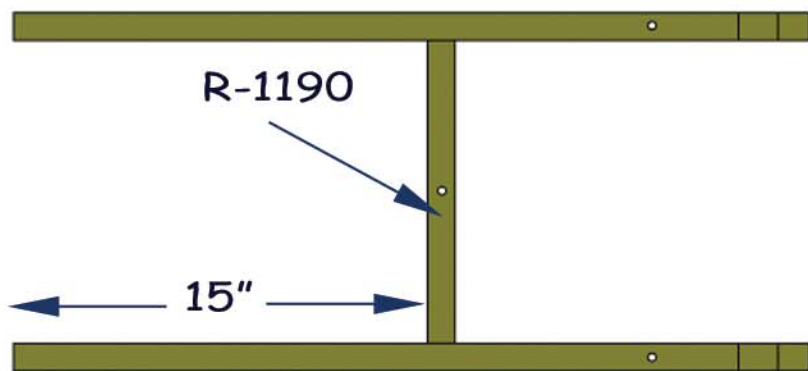

Iso View

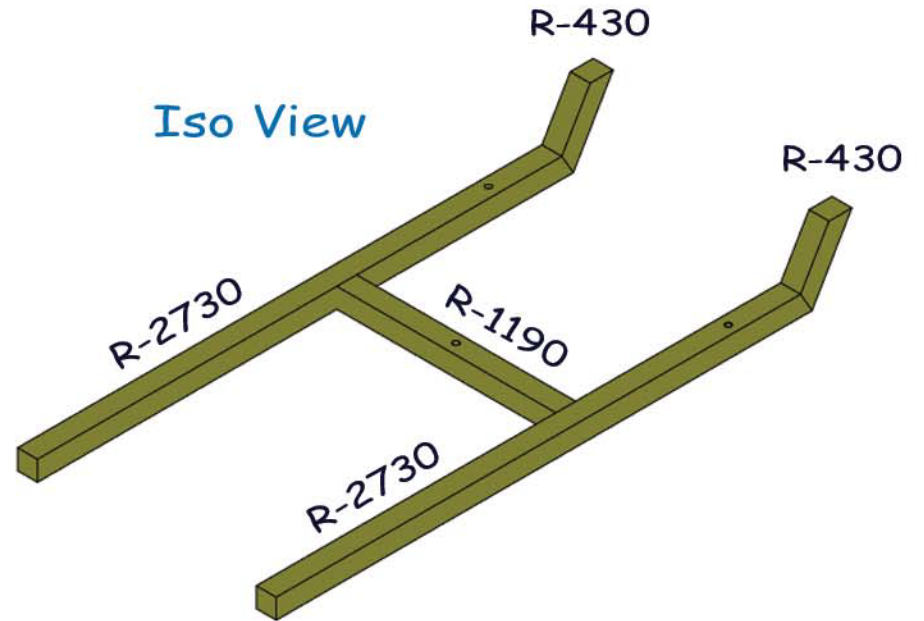

SPIDERCARTS	14		Ver.	0.1.2.6		Copyright is the property of Spidercarts and shall not be reproduced.
			Authorized	Robert Dicken		
		Base Frame		NA		

Side View

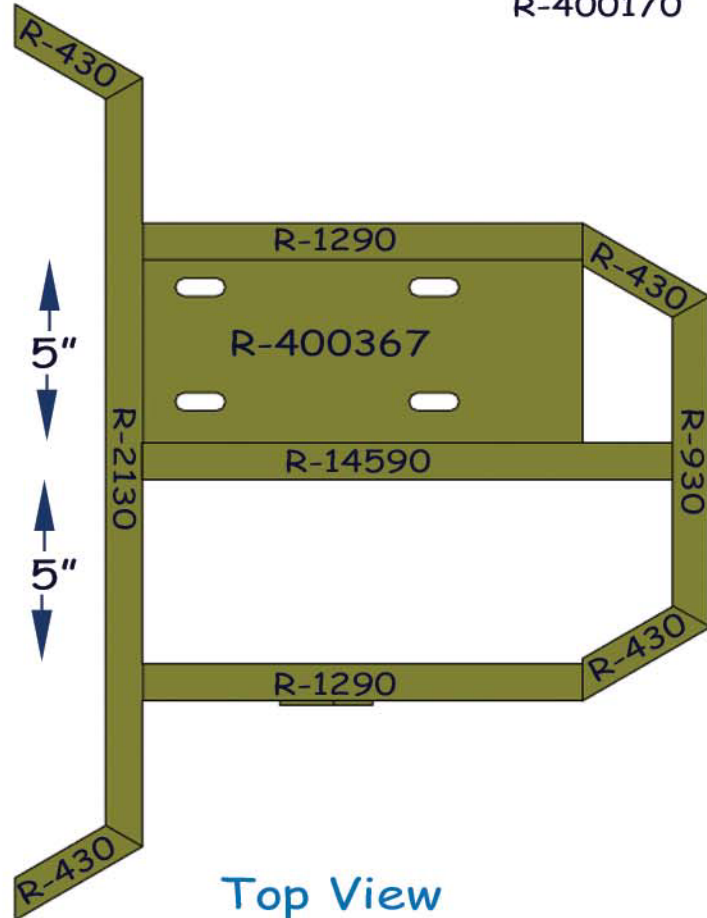
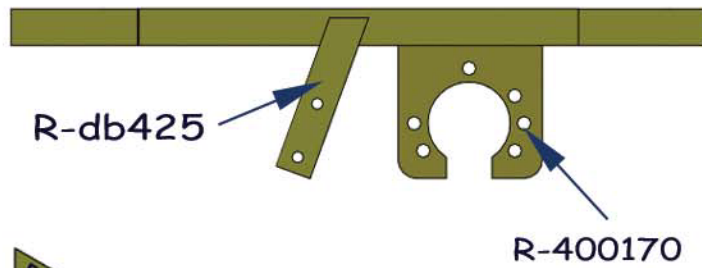

Top View

Notes

This is called the subframe. Lay it all out on a flat surface and double check all your cuts before welding. The brake bracket can be welded on when is best for you as well as the bearing hangers.

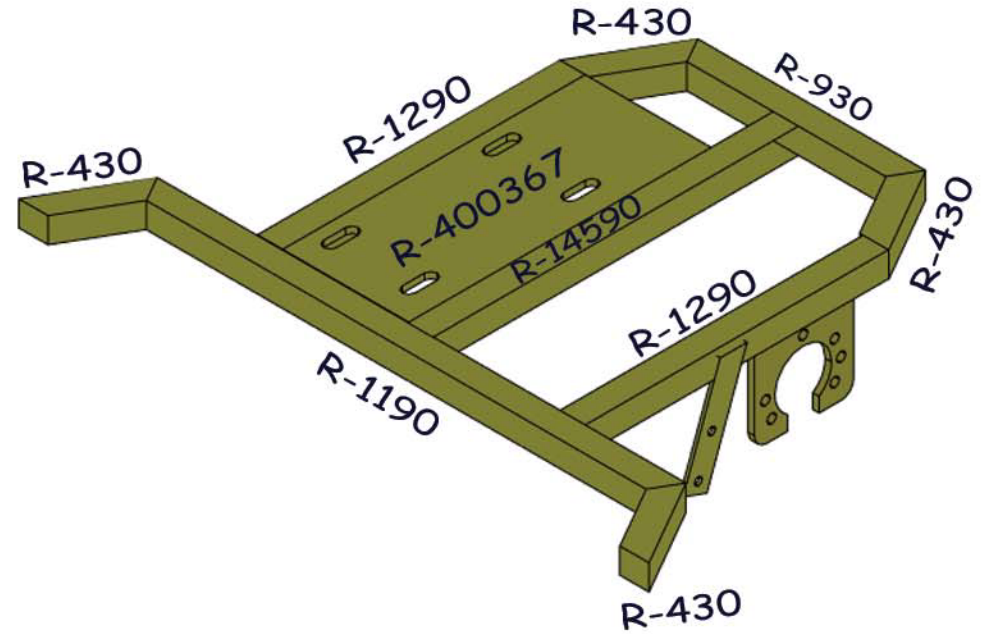

Iso View

SPIDERCARTS	15		Ver.	0.1.2.6	Copyright is the property of Spidercarts and shall not be reproduced.
			Authorized	Robert Dicken	
		SubFrame		NA	

Side View

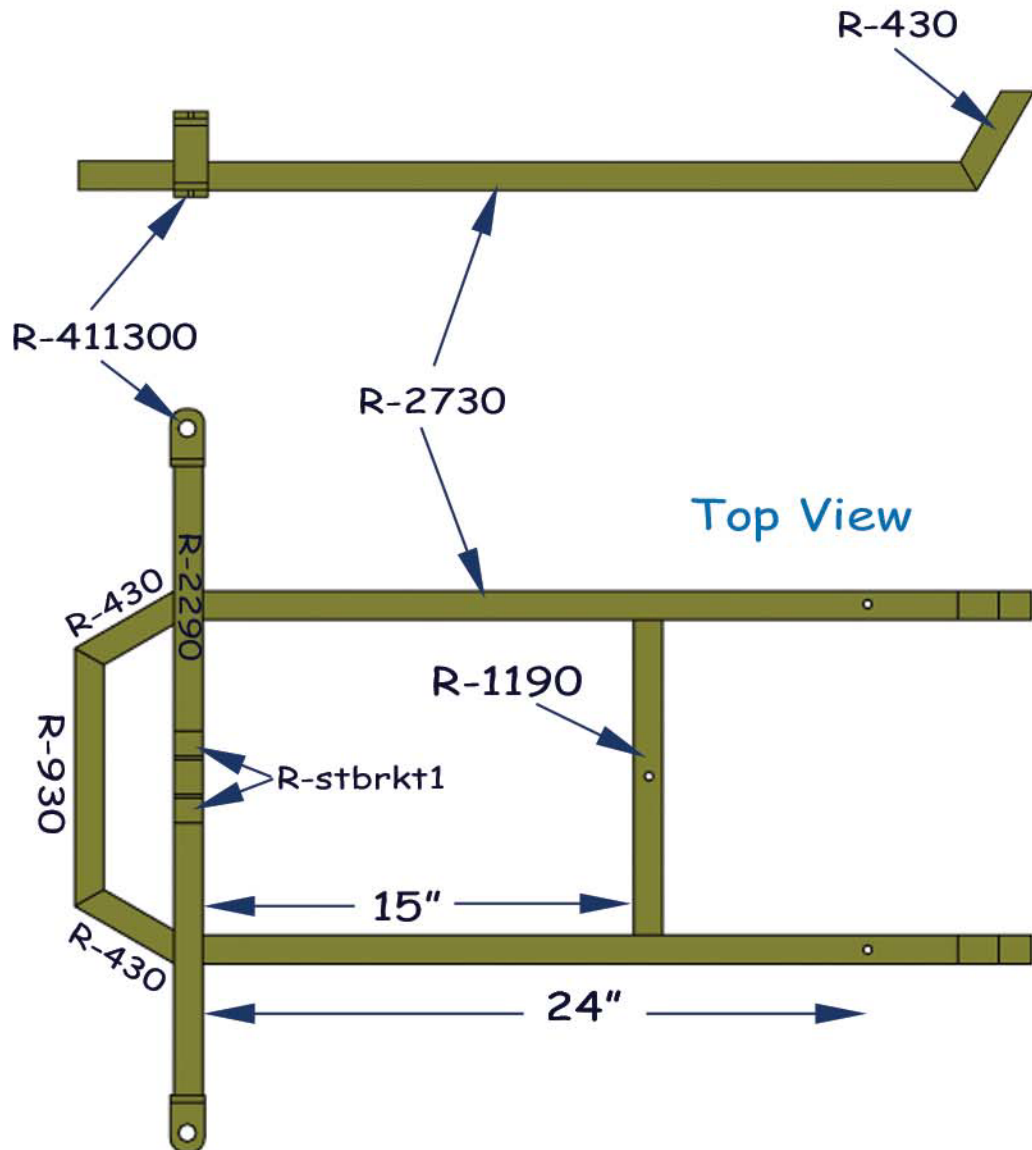

Front View

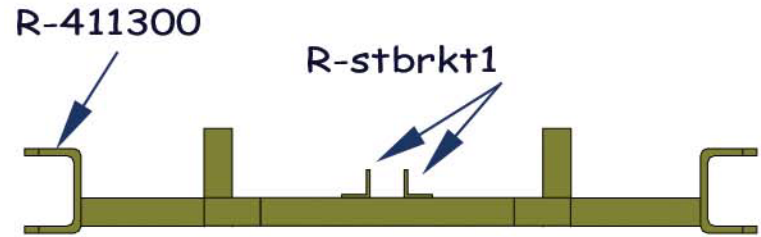

Top View

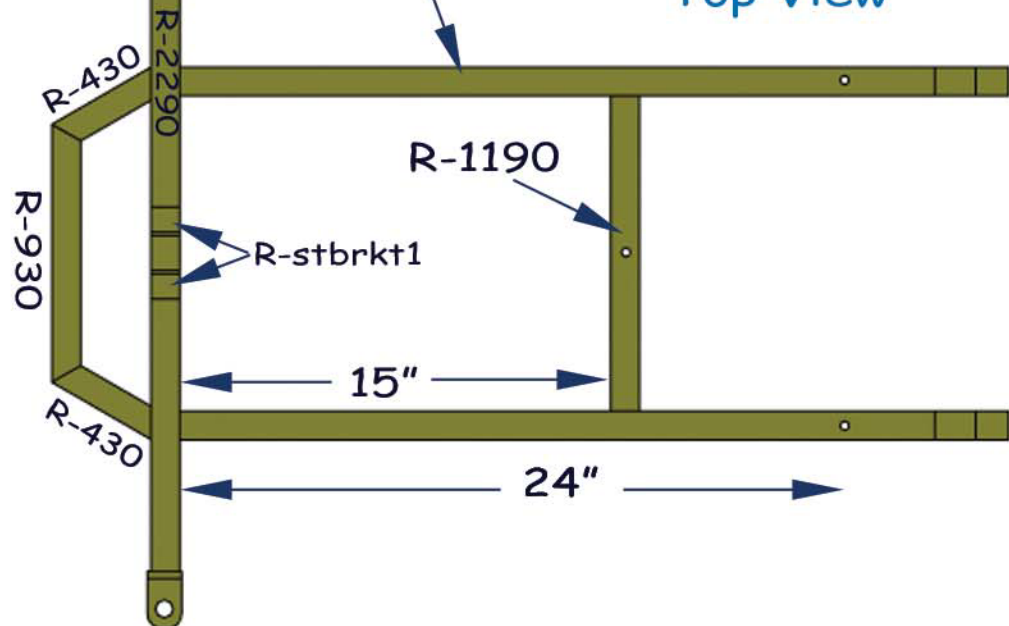

Iso View

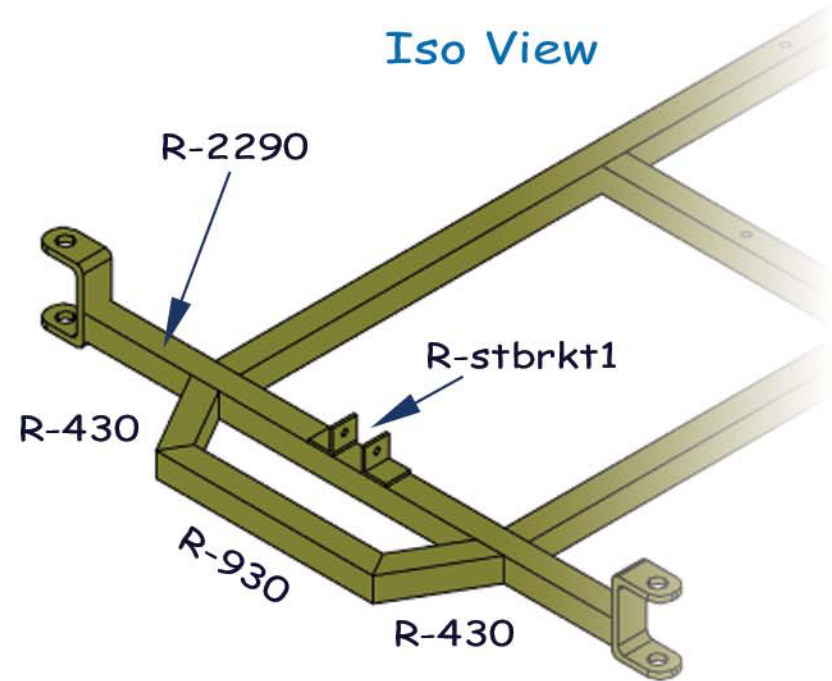

SPIDERCARTS	16		Ver.	0.1.2.6	Copyright is the property of Spidercarts and shall not be reproduced.
			Authorized	Robert Dicken	
	Base Frame II			NA	

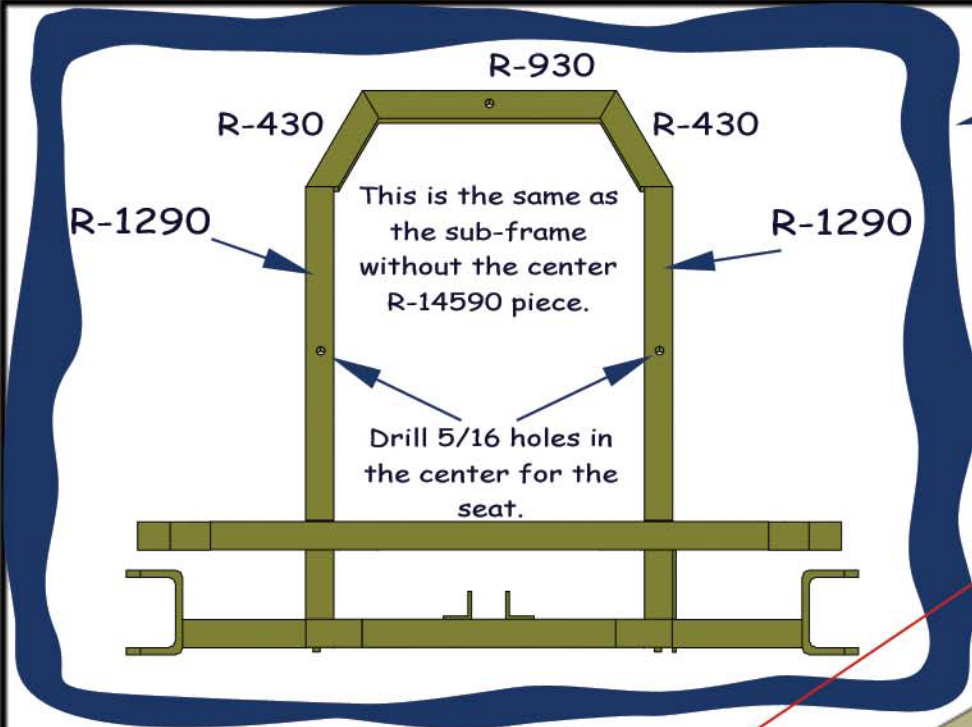

Roll Bar

Iso View

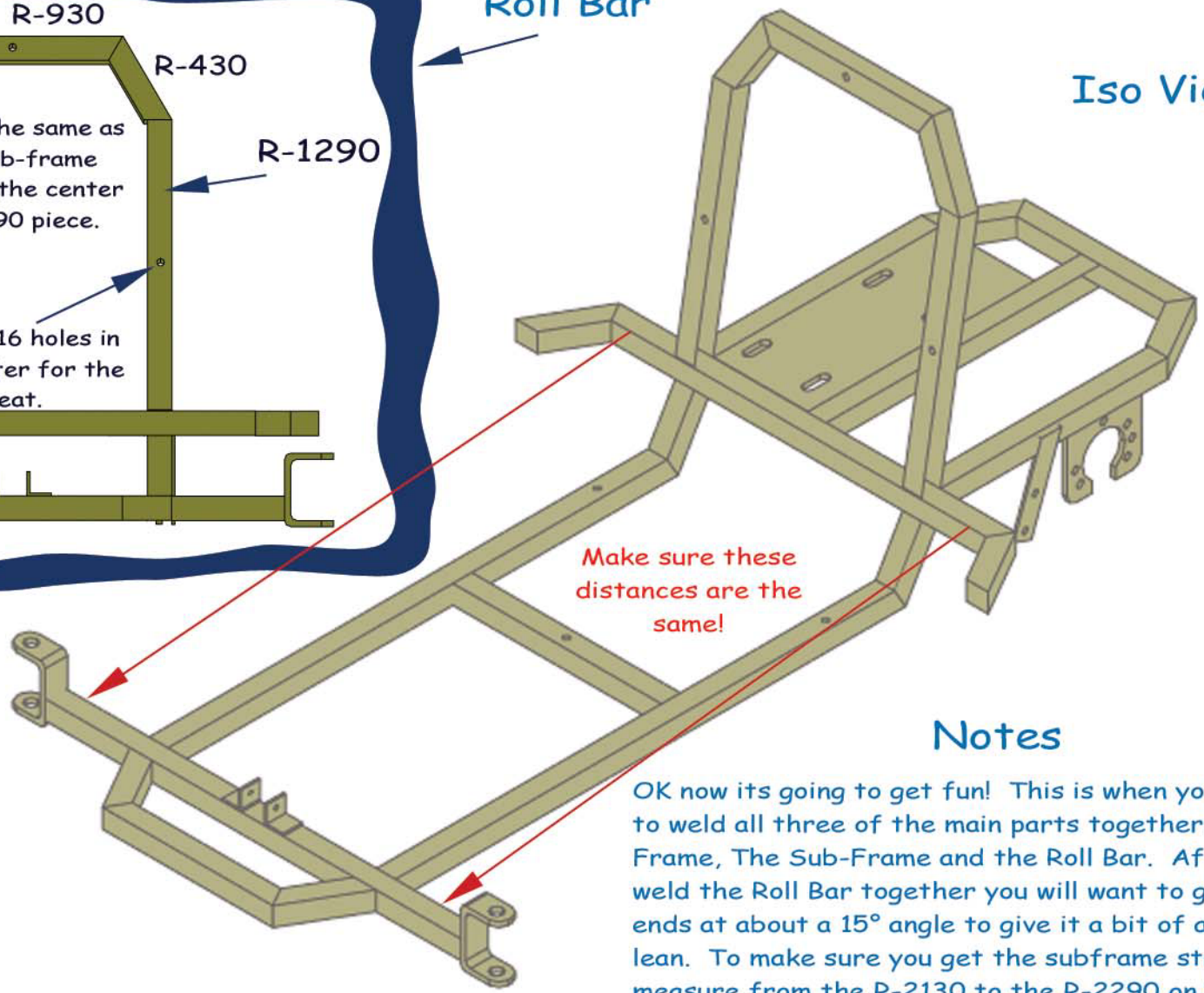

Notes

OK now its going to get fun! This is when you will want to weld all three of the main parts together. The Base Frame, The Sub-Frame and the Roll Bar. After you weld the Roll Bar together you will want to grind the ends at about a 15° angle to give it a bit of a backward lean. To make sure you get the subframe straight, measure from the R-2130 to the R-2290 on both sides and make sure they are the same. That will line up the two even if you are a bit off on some of your welds. Just make sure that measurement is right!

SPIDERCARTS	17		Ver.	0.1.2.6	Copyright is the property of Spidercarts and shall not be reproduced.
			Authorized	Robert Dicken	
	Roll Bar / Connect		NA		

Pictures



SPIDERCARTS			Ver.	0.1.2.6	Copyright is the property of Spidercarts and shall not be reproduced.
			Authorized	Robert Dicken	
			Pictures		

Pictures



SPIDERCARTS			Ver.	0.1.2.6	Copyright is the property of Spidercarts and shall not be reproduced.
			Authorized	Robert Dicken	
			Pictures		

Pictures



SPIDERCARTS

Ver.

0.1.2.6

Authorized

Robert Dicken

Pictures

Copyright is the property of Spidercarts and shall not be reproduced.

Motor Mount Plate

An engine mounting plate that allows the engine to be moved back and forth to remove the slack from the chain is needed. Most engines use the same mounting hole pattern. If you are going to make your own, follow the pattern shown in.

You'll need a way to cut the holes in the plate. A jig saw with a metal blade would work. Some have drilled lots of holes and then used files to cut away the rest of the material. A cutting torch would work as well. But buying the plate is often cheaper and much less of a pain. We purchased an 12" x 5" x 1/4" piece of metal in 2005 for \$9 locally. A parts house was selling a mounting plate for \$7 with pre-cut, pretty holes.

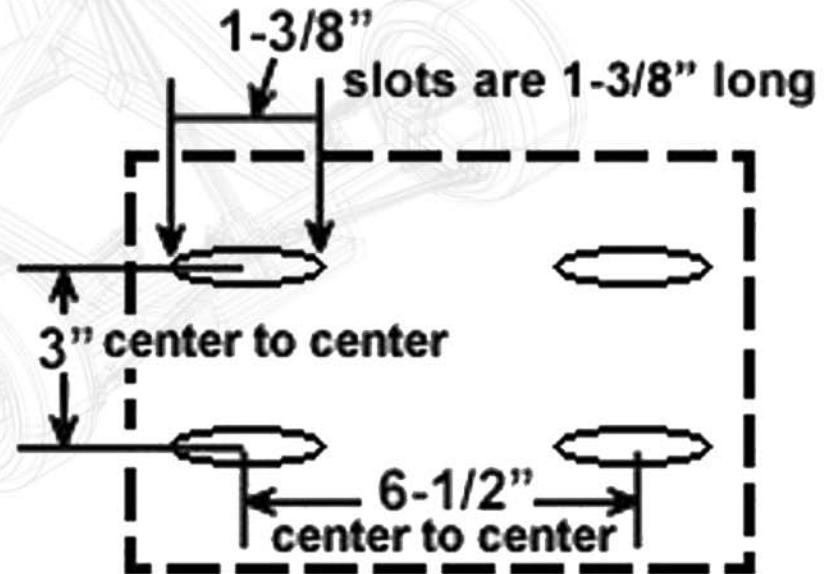
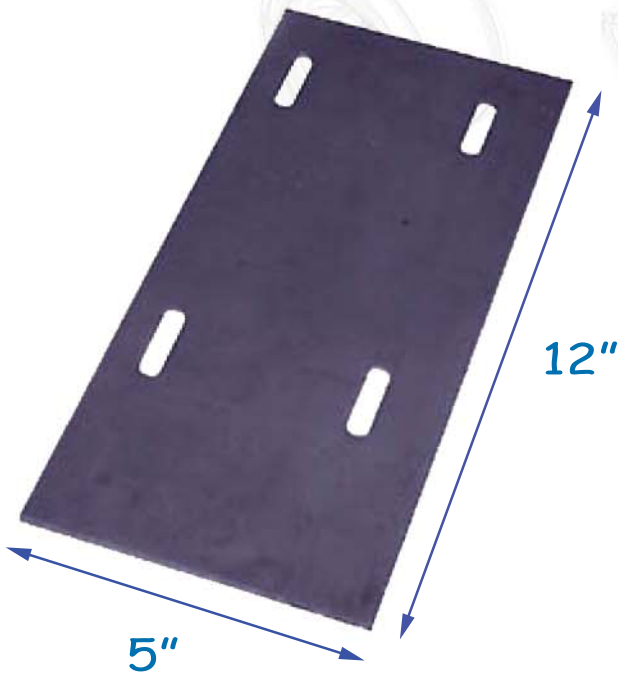

SPIDERCARTS	14		Ver.	0.1.2.6	Copyright is the property of Spidercarts and shall not be reproduced.
			Authorized	Robert Dicken	
	Motor Mount Plate		Qty - 1		

RECLUSE PARTS LIST

These parts are listed as reference only!

Please make sure the parts you purchase are the ones you need to fit your project as parts and prices may have changed.

Qty	Item	Price	Total	Vendor
2	Douglas 5.0 x 2.5 x 2.5 Polished Wheel	\$26.88	\$53.76	www.tsracing.com
2	Douglas 6 x 2.5 x 3.5 Polished Wheel	\$27.35	\$54.70	www.tsracing.com
2	MAXXIS HT3 10.5x450-6 Tire	\$41.40	\$82.80	www.tsracing.com
2	MAXXIS HT3 11.0x600-6 Tire	\$48.30	\$96.60	www.tsracing.com
4	2 Piece Steel Locking Collar 1" with Keyway	\$4.00	\$16.00	BMI Karts
1	Kill Switch	\$3.00	\$3.00	BMI Karts
1	Spindle Set	\$32.95	\$32.95	BMI Karts
2	Foot Pedals	\$5.95	\$11.90	BMI Karts
1	1" Bearing Kit (3 hole)	\$20.95	\$20.95	BMI Karts
1	Shock Mounting Tab	\$5.00	\$5.00	BMI Karts
2	Lightened Aluminum Front Racing Hub	\$12.00	\$24.00	BMI Karts
2	Lightened Aluminum Rear Hub	\$10.50	\$21.00	BMI Karts
1	Ultra-Lightweight Sprocket Hub - Star	\$27.95	\$27.95	BMI Karts
1	1" Brake Kit - Billet		\$0.00	BMI Karts
1	Plastic Steering Block - Lower	\$3.00	\$3.00	BMI Karts
1	Steering Wheel 10"	\$21.99	\$21.99	BMI Karts
1	Motor Mount 12" x 5"	\$5.95	\$5.95	BMI Karts
1	Keystock	\$1.45	\$1.45	BMI Karts
1	1" Billet Aluminum Live Axle 36"	\$35.00	\$35.00	BMI Karts
1	#41 Tooth 3/4 Bore Clutch	\$19.95	\$19.95	BMI Karts
5	Chain \$2.00/ft. x 5ft.	\$2.00	\$10.00	BMI Karts
1	Steering Shaft Kit	\$13.95	\$13.95	BMI Karts
1	Sprocket #41 54T	\$14.95	\$14.95	BMI Karts
1	Tecumseh 6hp Horizontal,7 Amp Alt / OHH60-71209-Alt	\$260.00	\$260.00	Small Engine Warehouse
Total			\$836.85	

Recluse Go-Kart Frame

www.spidercarts.com

Online Resources

Here are some of the best place we have found to get the parts needed to finish your kart. All of the parts needed can be purchased from these locations...

www.bmikarts.com

www.gokartsupply.com

www.mfgsupply.com

www.jackssmallengines.com

www.gokartnminibikeparts.com

Copyright © 2001 [Spidercarts.com]. All rights reserved.

Revised: 02/23/08..

Thank you for your business.

I hope you have found these plans to be helpful and complete.

Building go karts can be a very rewarding hobby.

As always please use caution when riding your new go kart and be safe.

Please check back with our website as we are always adding new products.

SPIDERCARTS			Ver.	0.1.2.6	Copyright is the property of Spidercarts and shall not be reproduced.
			Authorized	Robert Dicken	
	THANK YOU				